



## 5 Removal and Installation

⇒ [“5.1 One Piece Intake Manifold”, page 251](#)

⇒ [“5.2 Two Piece Intake Manifold”, page 265](#)

⇒ [“5.3 Engine Control Module J623 ”, page 279](#)

### 5.1 One Piece Intake Manifold

⇒ [“5.1.1 Intake Manifold”, page 251](#)

⇒ [“5.1.2 High Pressure Pump”, page 256](#)

⇒ [“5.1.3 Fuel Injectors”, page 259](#)

⇒ [“5.1.4 Fuel Injector Teflon® Seal and Washer”, page 262](#)

#### 5.1.1 Intake Manifold

**Special tools and workshop equipment required**

- ◆ Torque Wrench 5-50 Nm -V.A.G 1331-
- ◆ Puller for Ignition Coil -T10095 A-
- ◆ Socket TORX® T30 -T10347-



## Removing



## Note

- ◆ *Read the safety precautions before starting. Refer to ⇒ ["1.1 Safety Precautions", page 155](#) .*
- ◆ *Follow all the rules of cleanliness. Refer to ⇒ ["1.2 Clean Working Conditions", page 221](#) .*
- ◆ *If a fuel injector is removed, the combustion chamber Teflon® seal and the washer must be replaced. Refer to ⇒ ["5.1.3 Fuel Injectors", page 259](#) .*
- ◆ *The seal (-item 1- in the ⇒ ["2.1.2 Fuel Rail, Injectors and High Pressure Pump Overview, through 07.07", page 225](#) or -item 13- in the ⇒ ["2.1.3 Fuel Rail, Injectors and High Pressure Pump Overview, from 08.07", page 228](#) ) must also be replaced for the fuel injectors for cylinders 1, 3 and 5.*
- ◆ *If the fuel rail is removed, the fuel injector spring element -arrow- must be replaced.*
- ◆ *Fuel rail, injectors and high pressure pump overview, through 07.07. Refer to ⇒ ["2.1.2 Fuel Rail, Injectors and High Pressure Pump Overview, through 07.07", page 225](#) .*
- ◆ *Fuel rail, injectors and high pressure pump overview, from 08.07. Refer to ⇒ ["2.1.3 Fuel Rail, Injectors and High Pressure Pump Overview, from 08.07", page 228](#) .*
- ◆ *Intake manifold overview. Refer to ⇒ ["2.1.1 Intake Manifold Overview", page 223](#) .*

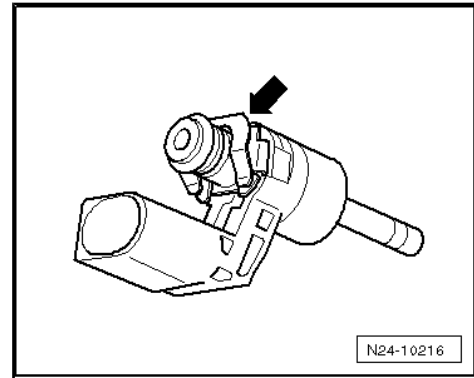

## Caution

*When doing any repair work, especially in the engine compartment, Pay attention to the following due to clearance issues:*

- ◆ *Route all lines and wires in their original locations.*
- ◆ *Make sure the wires have enough clearance to all moving or hot components.*



## WARNING

*Follow the safety measures for releasing the high side fuel pressure. Refer to ⇒ ["1.2 High Side Fuel Pressure, Releasing", page 156](#) .*

- Disconnect battery ground cable with the ignition turned off. Refer to ⇒ Electrical Equipment; Rep. Gr. 27 ; Removal and Installation .



- Disconnect the connectors -1-, remove the intake hose -2- and disconnect the connecting hose -3- for the crankcase ventilation from the cylinder head cover.

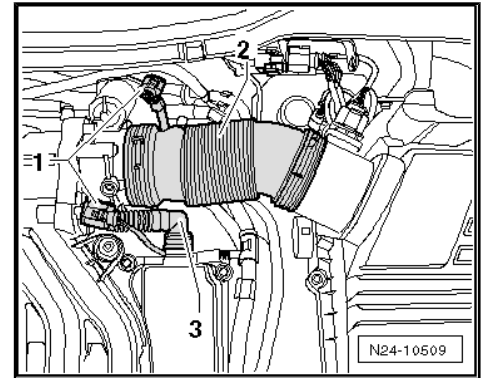

- Disconnect the connectors from the Ignition Coils With Power Output Stages -N70, N127, N291, N292, N323, N324- -1, 2, 3, 4, 5 and 6-.
- Remove the Ignition Coils With Power Output Stages . Refer to [⇒ "4.1 Ignition Coils with Power Output Stages", page 314](#) .
- Remove the wiring harness for the Ignition Coils With Power Output Stages from the intake manifold.
- Remove the high pressure pump. Refer to [⇒ "5.1.2 High Pressure Pump", page 256](#) .

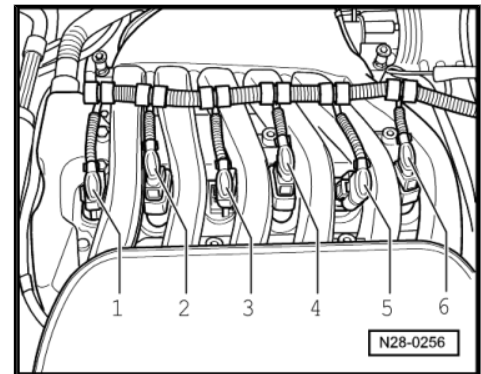

- Remove the fuel rail connecting line -arrows-.
- Remove the noise insulation. Refer to ⇒ Body Exterior; Rep. Gr. 50 ; Description and Operation .

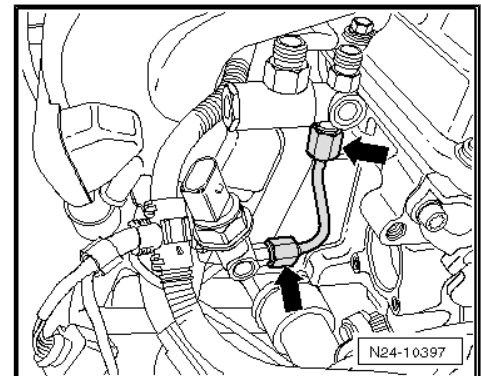

- Remove the bolt and disconnect the transmission fluid line -arrow- from the transmission. Catch the leaking transmission fluid with a cloth.
- Remove the front bumper cover. Refer to ⇒ Body Exterior; Rep. Gr. 63 ; Front bumper .
- Bring the lock carrier into the service position. Refer to ⇒ Body Exterior; Rep. Gr. 50 ; Description and Operation .

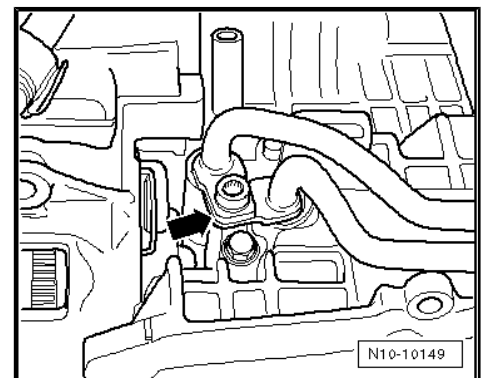



- Remove the oil dipstick guide tube bolt -1-.
- Remove the bracket -2- with the Intake Manifold Runner Control (IMRC) Valve -N316- -3- from the intake manifold.
- Disconnect the vacuum hoses -arrows- from the Intake Manifold Runner Control (IMRC) Valve -N316- -3-.

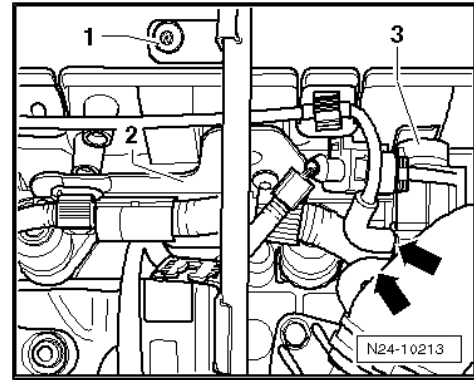

- Remove the left intake manifold support bolt -arrow-.

**Note***Ignore -1-.*

- Remove the throttle valve control module from the intake manifold.

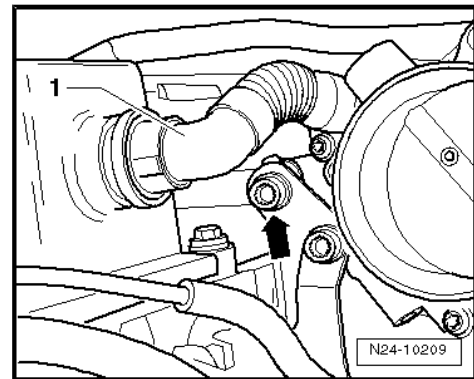

- Remove the right intake manifold support bolt -arrow-.

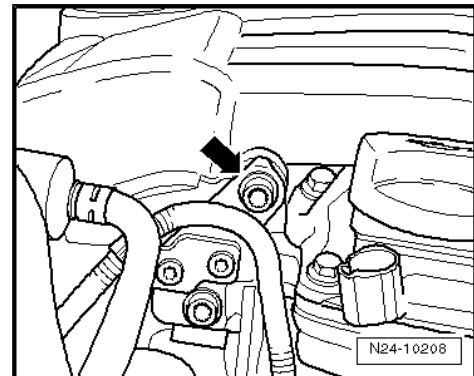

- Disconnect the lines -arrows- from the intake manifold.
- Unclip the line -2- from the retainer and move it out of the way.
- Remove the rear intake manifold support bolt -1-.

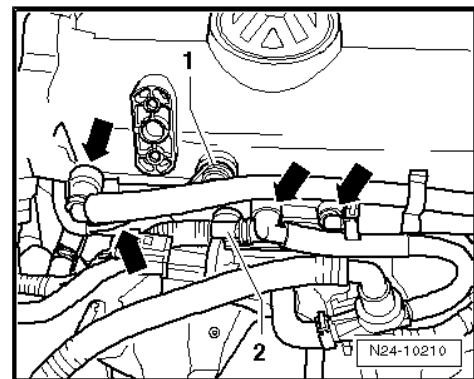



- Remove intake manifold to the cylinder head securing bolts -arrows- with socket TORX® T30 -T10347- .

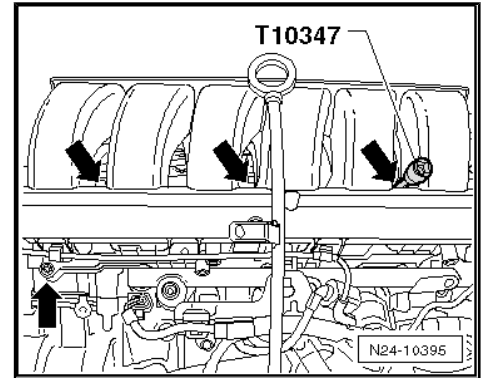

- Unscrew the bolts -arrows- for the fuel rail for cylinders 2, 4 and 6 .
- Carefully pull off the fuel rail from the fuel injectors.
- Remove the intake manifold downward and set it down on a suitable surface.

**Note**

- ◆ *If a fuel injector was removed from the cylinder head, then the Teflon seal must be replaced. Refer to ⇒ "5.1.4 Fuel Injector Teflon® Seal and Washer", page 262 .*
- ◆ *Seal the intake passages in the intake manifold and in the cylinder head using clean cloths.*

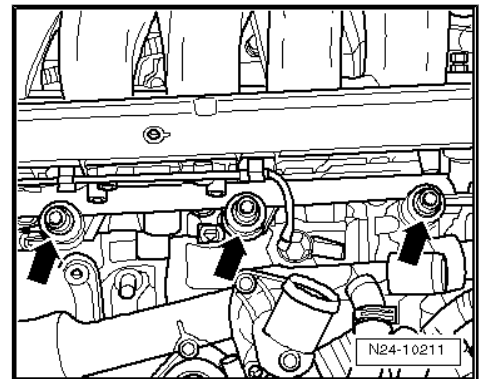
**Installing**

Installation is carried out in the reverse order while noting the following:

- Replace the O-rings between the fuel injectors and the fuel rail and lubricate them lightly with clean engine oil.
- Replace the spring element -arrow- on all the fuel injectors.
- Install the intake manifold.
- Place the fuel rail on and press it evenly onto the fuel injectors.
- Install all the bolts for the intake manifold and fuel rail by hand.

**Note**

- ◆ *First, evenly tighten the new fuel rail to cylinder head bolts working from the inside to the outside.*
- ◆ *Tighten the intake manifold to cylinder head bolts.*
- ◆ *Then, tighten the intake manifold support bolts.*

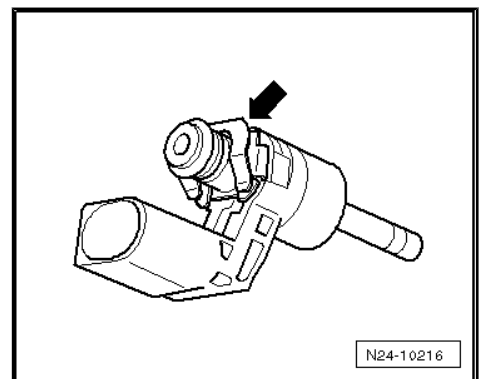



- Install the fuel rail connecting line -arrows-.
- Install the high pressure pump. Refer to ⇒ ["5.1.2 High Pressure Pump", page 256](#) .

**Note**

First tighten connecting line union nuts by hand and then tighten to specified tightening specifications.

- If necessary, fill with transmission oil. Refer to ⇒ Automatic Transmission; Rep. Gr. 37 ; General Information .

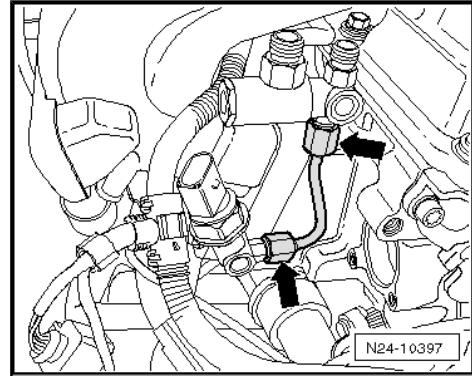

Tightening Specifications	Nm
Intake manifold to cylinder head bolts	8
Fuel rail to cylinder head bolts <sup>4)</sup>	30 Nm + 90°
Intake manifold to intake manifold support bolts	20
High pressure pump to cylinder head bolts	10
High pressure fuel line union nuts	22
Low pressure fuel line union nuts	27
Fuel rail connecting line union nuts	22

4) Always replace.

## 5.1.2 High Pressure Pump

### Removing

**WARNING**

- ◆ Follow safety measures for releasing the high side fuel pressure. Refer to ⇒ ["1.2 High Side Fuel Pressure, Releasing", page 156](#)
- ◆ The fuel pipes are under pressure. Always wear protective eyewear and protective clothing to prevent injuries and fuel from coming in contact with your skin. Before loosening the fuel pipes, place a cloth around the connection point. Then release pressure by carefully loosening.

- Remove the air guide cover -1- by disengaging the clips sideways to release it.
- Unclip the air duct -2-.

